

Morristown Utility Commission

Doing Business As  
Morristown Water System  
PWSID # 0000474

Standard Construction  
Specifications And Drawings  
For  
Pipeline Installation

Water Operations Office  
1833 Walters Drive  
Morristown, TN 37814  
Phone (423) 586-1346  
Fax (423) 586-1241

Commissioners:

George B. McGuffin , Chairman  
Harold L. Nichols, Secretary  
A.E. “Gene” Jolley, Member  
Max Biery, Member  
Lynn Elkins, Member

General Manager: William G. Swann, P.E.  
Water Operations Manager: Robert H. Garrett

# Table of Contents

## **Section 1**    **General Construction Information**

1. General Description of Work
2. Scope of Project
3. Subsurface Investigation
4. Plans and Specification
5. Licenses and Permits
6. Right-Of-Ways
7. Protection of Public and Private Property
8. Obstruction Shown and not shown
9. Operations along Highways and Streets
10. Operation of Existing Valves
11. Notices and Coordination with Other Agencies

## **Section 2**    **Excavation, Trenching, and Backfill**

1. Scope
2. Trenching
3. Stockpiling
4. Waste Materials
5. Blasting
6. Sheet piling and Bracing
7. Dewatering
8. Pipe Embedment
9. Backfill Material
10. Backfilling Trenching
11. Pavement Removal
12. Replacing Pavement
13. Maintenance of the Construction Area
14. Resodding and Seeding
15. Protection of Trees and Shrubs
16. Mail Boxes

## **Section 3**    **Installation of Pipe, Hydrants, and Services**

1. Installing Pipe
2. Installation and Replacement of Services
3. Installation of Hydrants
4. Testing
5. Disinfection
6. Temporary Service
7. Railroad Crossings
8. Thrust Blocks
9. Tie Rods

**Section 4 Valves and Accessories**

1. Scope
2. Gate Valves 2" or Smaller
3. Resilient - Seated Gate Valves 3" to 14"
4. Butterfly Valves 16" in Size and Larger
5. Air Valves
6. Blow-Off Valves

**Section 5 Fire Hydrants**

1. Scope
2. Hydrants
3. Hydrants Extensions

**Section 6 Valves Boxes, Manholes and Miscellaneous Metals**

1. Scope
2. Valve Boxes
3. Manholes
4. Miscellaneous Metal

**Section 7 Concrete**

1. Scope
2. Concrete

**Section 8 Ductile Iron Pipe and Fittings**

1. Scope
2. Pipe
3. Fittings

**Section 9 PVC Pipe 2" and 6" Only**

1. Scope
2. Pipe
3. Fittings
4. Special Instructions

**Section 10 Miscellaneous**

1. Scope
2. Water Services

**Section 11 Standard Specification for Materials**

**Section 12 Standard Detail Drawings**

## **Section 1 - General Construction Information**

1. General Description of Work
  - A. This work
    1. consists of furnishing and installing water mains, fire hydrants, customer service and appurtenances by MWS forces or others as shown in the plans and specified
    2. is to be performed at various locations in Hamblen County.
2. Scope of Project
  - A. This work consists of furnishing all materials and complete installation, including testing and placing in service.
3. Subsurface Investigation
  - A. The Commission has not performed any subsurface investigation.
  - B. All excavation is unclassified excavation.
4. Plans and Specification
  - A. Any conflict in the plans and specifications and applicable codes and standards, shall be referred to the Operations Office of Morristown Water System.
5. Licenses and Permits
  - A. All licenses shall be secured prior to start of work.
  - B. All permits for construction shall be obtained by MWS or contractor prior to start of construction.
6. Right-Of-Ways
  - A. All work performed by MWS will
    1. be on public right-of-way.
    2. be on right-of-way secured by MWS from private property owners.
  - B. All work performed by Contractor or others will
    1. be on public right-of-way.
    2. be on right-of-way secured by MWS from private property owners.
    3. be on private property.
7. Protection of Public and Private Property
  - A. Contractor shall be responsible for
    1. all damages to public and private property which are a result of their operations.
    2. repair to all property damaged immediately to the satisfaction of the owner of private property or the agency having jurisdiction over public property.
8. Obstruction (Shown and not shown) on plans prepared by MWS.
  - A. All known underground facilities which would affect MWS's operations have been shown on plans.
    1. to MWS's best knowledge.
    2. but are not guaranteed as to plans and elevations.
  - B. All obstructions shall be exposed in advance of trench excavations by Contractor.
    1. in order that they may be relocated, protected, or removed, as required.
    2. in order that lines and grades may be changed to by-pass them subject to approval of the Inspector.

9. Operations along Highways and Streets

- A. Contractor shall
  - 1. coordinate activities with the agency having jurisdiction of the facility.
  - 2. not open more than 300 feet of trench at any time without approval of the inspector.
- B. Contractor shall
  - 1. provide adequate barricades, signs, and flagmen to protect the public from traffic hazards.
  - 2. provide the above protection subject to the approval of the agency having jurisdiction and MWS's Inspector.
- C. The MWS Inspector shall retain the authority to
  - 1. require Contractor to provide additional barricades, warning signs, and lights as necessary.
  - 2. halt Contractor operation when they deem unsafe for the public protection.

10. Operation of Existing Valves

- A. The operation of all existing valves of the distribution system shall be under the supervision of the Inspector.

11. Notices and Coordination with Other Agencies

- A. Contractor shall
  - 1. notify and coordinate with all parties and agencies which will be affected their operations.
  - 2. obtain copies of permits for construction , referred to 1-5,B.
  - 3. comply with the Regulations of the Department of Commerce (Title15 Code of Federal Regulation, Part 8) relative to non-discrimination when working under a Tennessee Highway Department permit.

## **Section 2 - Excavation , Trenching, and Backfill**

1. Scope
  - A. Includes all requirements pertaining to site clearing, trenching, subgrade preparation, sheeting and bracing, pipe embedment, backfill, and compaction for the installation of mains, hydrants, services, and appurtenances.
  - B. Includes all other earthwork required to complete the work as specified.
2. Trenching
  - A. Materials encountered shall be
    1. removed as required for alignment and grade of work as shown.
    2. unclassified excavation.
  - B. Side walls shall be
    1. vertical or sloped within specified trench width limitations below top of pipe.
    2. vertical or sloped or stepped as required for stability above the pipe.
    3. sheeted and braced where necessary.
    4. excavated without undercutting.
  - C. Equipment and methods shall be
    1. optional where structures or other facilities are not endangered.
    2. subject to approval of the Inspector where stability or usefulness of other facilities may be impaired.
  - D. Length of open trench shall
    1. be in advance of pipe laying only as far as permitted by the Inspector.
    2. not exceed 300 feet at any time unless otherwise approved by the Inspector
    3. be closed at night unless otherwise approved by Inspector.
  - E. Depth shall
    1. be sufficient to provide a minimum cover of 36 inches unless otherwise specified by profiles in the drawings.
    2. be increased as necessary to remove unsuitable supporting materials.
    3. be at least 8 inches below bottom of pipe when excavation in rock.
  - F. Bottom of trench shall be
    1. protected and maintained when suitable natural materials are encountered.
    2. restored to proper elevation with stabilization material when over-excavated.
    3. cleaned of rock fragments and loose uncompacted material.
  - G. Stabilization material shall be
    1. crushed rock, gravel, or sand
      - (a) 95% + passing 1/2 sieve.
      - (b) approved by Inspector.
    2. compacted inlayers not exceeding 6 inches
      - (a) with pneumatic or vibratory equipment.
      - (b) to approved firm conditions.
  - H. Width of trench shall be
    1. ample for proper pipe installation and backfilling.
    2. in accordance with the following table, unless otherwise approved:

Nominal Pipe Size	Minimum Width
6	30
8	32
12	36
16	40
18	42
24	48
30	54

3. Stockpiling shall
  - A. not obstruct or prevent access to

1. roads or driveways.
    2. utility control devices
    3. ditches or natural drainage channels.
  - B. be performed in a manner to avoid endangering
    1. the work.
    2. stability of banks or structures.
    3. health of trees.
4. Waste Materials shall
- A. include all excess usable materials.
  - B. consist of unsuitable materials.
  - C. be disposed of at off site locations arranged for by the Contractor.
5. Blasting shall be
- A. in conformance with all local and state safety codes.
  - B. performed to avoid shattering rock beyond required limits of trench or excavation.
  - C. with charge holes properly located and drilled to correct depth for charges used.
  - D. with charges limited in size as required to permit reasonable removal of material by excavating equipment.
    1. with "outbreak" effects corrected
      - (a) by removal of broken rock, and
      - (b) replacement with approved material.
  - E. conducted under cover of mats in congested areas or in proximity to facilities subject to damage.
6. Sheeting and Bracing shall be
- A. used in open cuts as required
    1. by state laws and local ordinances.
    2. to conform with recommendations set forth in AGC manual of Accident Prevention in Construction.
    3. to protect life, property , or the work.
    4. to avoid excessively wide cuts in unstable material.
  - B. removed simultaneously with backfilling, except where otherwise approved.
  - C. left in place when required by condition of supported material.
  - D. cut off at approved elevation below the surface when left in place.
  - E. replaced with sand or other approved material in voids left after withdrawal.
7. Dewatering shall
- A. be aided by grading and stockpiling as necessary to divert surface water form excavations.
  - B. be accomplished by draining or pumping immediately when water appears, and continuously if necessary.
  - C. be discharged to approved drains or natural channels.
  - D. include removal of subgrade material rendered unsuitable because of excess water, and replacement with trench stabilization material.

8. Pipe Embedment shall
  - A. be required when excavation is in rock.
  - B. be required when specified on the plans or other parts of this specification.
  - C. be crushed rock or gravel 95% + passing 3/4" sieve, and 100% passing 1-1/2" sieve when required for Ductile Iron.
  - D. be placed so that the bottom layer
    1. has a minimum depth of 4 inches below the pipe barrel when excavation is in earth
    2. has a minimum depth of 8 inches below the pipe barrel when excavation is in rock.
    3. is at proper elevation to uniformly support the pipe barrel throughout its length.
  - E. be placed so that the top of the layer is at the elevation of the center line of the pipe
  
9. Backfill Material
  - A. shall be obtained from
    1. trench excavation.
    2. borrow pits at locations arranged and paid for by Contractor.
  - B. shall be free from vegetable material, organic matter, refuse, ashes, cinders, boulders, rocks, broken pieces of pavement, frozen or other material considered unsuitable by Inspector.
  - C. shall contain sufficient moisture and fine material to provide dense mass free of voids and to obtain a minimum compaction of 95%.
  - D. for PVC shall consist of
    1. embedment material or earth fill containing no stones or gravel larger than that allowed in embedment material from the bottom of the trench to one (1) foot above the top of pipe.
    2. earth fill containing an occasional stone or broken piece of pavement no larger than 4 inches in any dimension from 1 foot above the pipe to the sub-grade of the pavement.
  - E. for ductile iron shall consist of
    1. embedment material only from the bottom of the trench to center line elevation of the pipe.
    2. earth fill containing an occasional stone or broken piece of pavement no larger in any dimension than 6 inches from the center line elevation of the pipe to the subgrade of the pavement, care being taken that no large stone or broken piece of pavement is placed within 12 inches of the pipe.
  - F. shall be approved by the Inspector before placing.
  
10. Backfilling Trenches shall
  - A. proceed behind trench excavation and pipe laying operations so that
    1. length of open trench shall not exceed 300 feet at any time unless otherwise approved by the Inspector.
    2. all drives and streets crossed by trench are open to traffic at end of work day.
    3. safe travel at night can be made.
  - B. be compacted above the center line of the pipe or top of the trench in all drives or streets crossed.
    1. with approved mechanical equipment.
    2. in layers of thickness within compacting ability of equipment used.
    3. to density adequate to prevent significant future settlement.
    4. to the satisfaction of the agency having primary jurisdiction of the facility
    5. to the satisfaction of the Inspector.

## 11. Pavement Removal

- A. Concrete pavements shall be
  - 1. cut in a manner to prevent
    - (a) spalling at edges of cut.
    - (b) random and erratic cracking.
- B. All pavements
  - 1. shall be cut to a width
    - (a) as required by the agency having jurisdiction of the pavement, or as shown in detail for pavement repair.
    - (b) one foot beyond the outside edge of excavation for
      - (i) concrete vaults
      - (ii) anchor bolts
      - (iii) other appurtenances.
    - (c) undermined during construction operations shall be
      - (i) removed to straight lines square with the pavement joints.
      - (ii) removed back to area of firm ground.
- C. Necessary permits for cutting pavement shall
  - 1. be obtained before cutting pavements and copies in the possession of the Inspector.
  - 2. be obtained by the contractor from the Agency.
- D. Contractor shall confirm to all requirements of the agency having jurisdiction of the pavement, and shall obtain said requirements from the agency prior to cutting pavement.

## 12. Replacing Pavement

- A. all pavement and other surface of streets, roads, driveways, etc., and all curbs and sidewalk cuts, damaged, or removed shall be
  - 1. replaced to their original or better state and condition.
  - 2. replaced with new materials.
  - 3. replaced according to requirements of agency having primary jurisdiction of the facility, or as shown in detail for pavement repair.

## 13. Maintenance of the Construction Area

- A. During construction and until completion of pavement replacement contractor shall be required to
  - 1. add materials to the trench as often as necessary to assure safe vehicular passage.
    - (a) to the satisfaction of the Inspector.
    - (b) to the satisfaction of the agency having primary jurisdiction of the facility.
  - 2. remove rubbish, dust, mud, dirt, and gravel by means of hand broom and/or flush trucks as often as necessary to avoid creating a public nuisance
    - (a) to the satisfaction of the Inspector.
    - (b) to the satisfaction of the agency having primary jurisdiction of the facility.

## 14. Resodding and Seeding

- A. All established lawn and grassed areas cut by the line of trench shall be resodded or seeded
  - 1. after completion of job.
  - 2. to the satisfaction of the Inspector.
- B. All sod shall
  - 1. be of the same type removed or damaged.
  - 2. be best grade.
  - 3. be live, fresh growing grass when placed.
  - 4. have at least two inches of soil adhering to roots.
  - 5. be replaced by experienced personal and maintained until growth is established.
- C. All topsoil dressing and seeding shall be
  - 1. in accordance with good practice.
  - 2. with the approval of the Inspector.

## 15. Protection of Trees and Shrubs

- A. Trees and Shrubs

1. shall not be removed where outside excavation limits.
  2. damaged or removed by Contractor shall be replaced.
    - (a) to the Inspector's satisfaction
    - (b) and maintained until growth is established.
- B. Trimming of standard trees where required shall be as directed by Insp.
16. Mail Boxes shall be replaced as required to the satisfaction of the Inspector.

### **Section 3 - Installation of Pipe, Hydrants, and Services**

1. Installation of Pipe
  - A. Handling and storage of pipe and fittings shall be
    1. with care to avoid damage to pipe and lining,
    2. so that pipe units are kept from contact with adjacent units by means of wooden blocks.
    3. in a manner to keep interior of pipe free from dirt, foreign material and ground water.
  - B. Laying of pipe shall be
    1. be in manner that the pipe is uniformly supported through out its entire length on the bottom quadrant.
    2. be subject to the approval of the Inspectors as pertains to the method of laying and inspection of pipe for damage.
    3. not be on blocks.
    4. include the interior cleaning by use of a ram brush or other approved methods immediately prior to installation.
    5. be at least 10' horizontally from any sanitary sewer, storm sewer, or sewer manhole where conditions allow.
    6. provide 18" vertical separation between water and sewer lines in the event of crossing where conditions allow.
    7. be so that when conditions prevent a 10 foot horizontal separation the bottom of the water main must be at least 18 inches above the top of the sewer. Water and sewer pipes cannot be in the same trench.
    8. be so that if water mains must cross under sewers there must be at least 18 inches separation and the length of water pipe shall be centered so that the joints are equidistant and as far as possible from the sewer.
  - C. Pipe shall be cut using
    1. hydraulic cutters - cast iron only.
    2. a Carborundum saw - ductile.
    3. other approved methods for 12" and larger in diameter.
  - D. Pipe shall be protected at the end of each work day by
    1. a plug of the same diameter placed in the pipe and secured by at least two bolts or set screws.
    2. a test plug of the cone-lock or wedge lock variety,
    3. other methods as approved by the Inspector.
  - E. All dead end mains will be provided with a fire hydrant or blow-off.
2. Installation and Replacement of Services shall be completed by MWS forces and cost of replacement will be incurred by Contractor.
3. Installation of Hydrants
  - A. Hydrants shall be
    1. connected to the main with a 6" ductile iron branch.
    2. installed with a 6" gate valve in the branch.
    3. installed such that the branch piping and the hydrant shoe have uniform bearing.
    4. as specified in Division 5
    5. aligned vertically or plumbed to the satisfaction of the Inspector.
    6. installed with extensions as specified in Division 5 when required by the Inspector.
    7. installed according to the typical installation detail shown in Standard Drawings of these specifications unless otherwise directed by the Inspector.
    8. installed with thrust block as shown in Standard Drawings or as directed by the Inspector.

- B. Hydrant drainage shall be provided
  - 1. in impervious soil by
    - (a) excavating a pit 2' x 3'.
    - (b) filling compactly the pit with crushed stone and around the elbow of the hydrant above the top of the hydrant flange on the shoe or as directed by the Inspector.
- 4. Testing
  - A. All mains, hydrants, and services shall be
    - 1. tested at 150 psig, unless otherwise specified.
    - 2. tested under the supervision of the Inspector.
  - B. All mains, hydrants, and services shall be tested in accordance with AWWA Standard C600-82, or latest revision, for Installation of Ductile Iron Water Main, Section 4.
- 5. Disinfection
  - A. All mains, services, and hydrants shall be disinfected using the continuous feed method in accordance with AWWA Standard C601-81, Section 5.2, or latest revision.
- 6. Temporary Service
  - A. Contractor shall provide temporary installation in order to provide continuous service to customers where re-laying operations are being conducted.
- 7. Railroad Crossings
  - A. All railroad crossings shall
    - 1. be tunneled, bored, or jacked.
    - 2. be encased as shown on the plans.
    - 3. be installed in accordance with the appropriate railroad's specifications.
- 8. Thrust Blocks
  - A. Shall be required for all tees, bends, offsets, and dead ends
  - B. Shall be poured against undisturbed earth.
  - C. Shall be enlarged as directed by the Inspector if poured against backfill or unstable soil.
  - D. Shall be dimensioned as shown in the thrust block detail of specifications.
  - E. Shall be constructed of concrete as specified in Division 7
  - F. Shall be set for three days prior to placing main and appurtenances in service.
- 9. Tie Rods
  - A. Shall be required on all fire hydrants as directed by the Inspector.
  - B. Shall be used on bends, valves and offsets as directed by the Inspector.
  - C. Shall be coated with a bitumasatic black paint.

#### **Section 4 - Valves and Accessories**

1. Scope
  - A. Provides for all labor, equipment, and materials necessary to furnish and install
    1. line valves.
    2. air relief and vacuum valves.
    3. line blow off valves.
  - B. Provides for installation of valve boxes and manholes as specified on plans and other divisions of this specification.
2. Gate Valves 2" or Smaller in Size shall be
  - A. As specified in Division 11 of these specifications.
  - B. installed in valve boxes unless otherwise specified.
3. Resilient - Seated Gate Valves 3" to 14" in Size shall
  - A. be for water working pressure not less than 150 psi.
  - B. be as specified in Division 11 of these specifications.
  - C. be installed in valve boxes unless otherwise specified.
4. Butterfly Valves 16" in Size and Larger shall
  - A. be as specified in Division 11 of the specifications.
  - B. be installed with valve boxes unless otherwise specified.
5. Air Valves shall
  - A. be as specified in Division 11 of these specifications.
  - B. be 1" on pipelines 12" in diameter and smaller and 2" on pipelines 14" in diameter and larger.
  - C. be located at all high points on the pipeline and in manholes or as directed by the Inspector.
  - D. be installed in accordance to detail in Standard Drawings of these specifications unless otherwise directed by the Inspector.
6. Blow-Off Valves shall
  - A. be as specified in Division 11 of these specifications.
  - B. be 2" in size unless otherwise directed by the Inspector.
  - C. be installed in accordance with detail as shown in Standard Drawings or as directed by the Inspector.

## **Section 5 - Fire Hydrants**

1. Scope
  - A. Provides for all labor, equipment and material necessary to furnish and install traffic type hydrants.
  - B. Provide for fire hydrants extensions as required.
2. Hydrants shall
  - A. be as specified in Division 11 of these specifications.
  - B. be designed for water working pressures not less than 150 psi.
  - C. be installed in accordance to Division 3, Section 3 of these specifications.
3. Hydrant Extensions shall
  - A. be as specified in Division 11 of these specifications and be used when required to place the hydrant nozzles at the proper elevation as determined by the Inspector.
  - B. be compatible with the fire hydrant being adjusted.
  - C. be installed with one set of shear bolts in the top flange and machine bolts in the bottom flange.

## **Section 6 - Valve Boxes, Manholes and Miscellaneous Metals**

1. Scope
  - A. Furnishing all necessary materials and labor for installing valve boxes and manholes
2. Valve Boxes shall be
  - A. made to conform to Division 11, Castings, of these specifications.
  - B. installed in accordance with Standard Drawings of these specifications.
  - C. installed with the opening centered over the valve operating nut.
3. Manholes shall be
  - A. of the following materials
    1. number 1, common building brick as specified in Division 14.
    2. mortar composed of one part Portland cement and hydrated lime to two parts sand. Hydrated lime shall be 10% of cement.
    3. sand shall pass a screen test of not less than 10 meshes per linear inch.
  - B. set even with the paved surface when set in streets and driveways.
  - C. set 6" above grade when located in unpaved areas or as directed by the Inspector.
4. Miscellaneous Metal
  - A. Includes
    1. all cast iron frames
    2. manhole covers
    3. manhole steps
    4. valve boxes
    5. meter box lids
    6. valve box lids
  - B. An item composed of more than one unit shall
    1. have units interchangeable with all other items.
    2. not consist of selective fits of the various parts.
  - C. shall be approved by the inspector before installation.

## **Section 7 - Concrete**

1. Scope
  - A. Furnish and place necessary concrete for thrust blocks, gravity blocks, vaults, and miscellaneous structures.
2. Concrete
  - A. Design of mix shall
    1. have minimum compressive strength of 2,500 psi at seven days.
    2. have a minimum compressive strength of 4,000 psi at 28 days when tested in accordance with ASTM Standard C39.
    3. be by a competent laboratory
      - (a) at contractors expense
      - (b) of 3" maximum slump, unless otherwise specified
      - (c) with the following information submitted to the Inspector for approval.
        - (i) seven day and 28 day compressive test results on the primary mix
        - (ii) gradation of fine and coarse aggregate and the percent of inorganic and organic impurities in each.
        - (iii) source of fine and coarse aggregates.
        - (iv) brand name of cement.
  - B. Ready-Mix concrete may be used provided
    1. above requirements are met.
    2. truck mixers are equipped so that mixing time, number of revolutions of the mixer and amount of water added to the batch can be readily verified by the Inspector.
  - C. Material shall consist of
    1. fine and coarse aggregate conforming to Federal Specification SS-A-281A, Grade A.
    2. Portland cement conforming to ASTM Designation C-150, Type I or Type II, of good quality.
    3. reinforcing steel conforming to ASTM Designation A-15, with deformations conforming to ASTM Designation A-305.
    4. water, clean and free from injurious amounts of oil, acid, alkali, organic matter or other deleterious substances.
  - D. Placing of reinforcing steel shall be
    1. accurate as shown on plans.
    2. tied at all intersections.
    3. supported on chairs.
    4. at a minimum clear distance of
      - (a) 3" between steel and unformed surfaces on contact with earth.
      - (b) 2" between steel and formed surfaces on contact with earth.
      - (c) 1' 1/2" between steel and all other formed surfaces.
  - E. Placing of concrete shall be
    1. withheld until forms and reinforcement have been inspected by the Inspector.
    2. compacted with aid of mechanical vibrators, rods, slicing bars, etc.
    3. without honeycomb and large air bubble marks on surface.
  - F. Protection and curing shall be
    1. immediately after placing and finishing.
    2. provided for all concrete surfaces not covered by forms.
    3. by use of wet mats or burlap, or other approved methods.
  - G. Testing shall
    1. be made by Contractor as directed by the Inspector.
    2. be in conformance with ASTM Designation C-39.

## **Section 8 - Ductile Iron Pipe and Fittings**

1. Scope
  - A. Includes the furnishing of ductile iron pipe.
  - B. Includes all plugs, flanges, jointing materials, specials, and appurtenances, required for the complete installation of the pipe fittings.
  
2. Pipe shall
  - A. as specified in Division 11 of these specifications.
  - B. be slip joint pipe unless otherwise directed by the Inspector.
  - C. have a wall thickness in accordance with the plans and other parts of this specification: Class 50 for all sizes
  
3. Fittings shall
  - A. be as specified in Division 11 of these specifications.
  - B. be short body ductile iron.
  - C. be furnished with mechanical joint unless otherwise directed by the Inspector.

**Section 9 - PVC Pipe - 2" and 6" Only**

1. Scope
  - A. Includes the furnishing of pvc pipe and fitting as required.
  - B. Includes all plugs, couplings, jointing materials, specials, and appurtenances, required for the complete installation of the pipe and fittings.
2. Pipe shall
  - A. be as specified in Division 11 of these classifications.
3. Fittings shall
  - A. be class 200 pressure PVC gasket joint "O" ring bell joint for Water service.
4. Special Instructions
  - A. Copper wire, size 14, solid insulated cover type THHN, will be installed the full length of the pipeline 1 foot above the pipe and tied to each gate valve.

**Section 10 - Miscellaneous**

1. Scope
  - A. Specify miscellaneous materials required to complete job as outlined on the plans and in other Divisions of this specifications.
2. Water services connections shall be made by MWS

## Section 11 – Standard Specifications for Materials

### Index

Specification #	Description
100	3" – 64" Slip Joint Ductile Iron Pipe
150	2" – 8" PVC Pipe Class 200
200	2" – 16" Slip or Mechanical Joint, Resilient Seated Gate Valves
210	3" – 12" Tapping Valves
300	3" – 24" Mechanical Joint, Compact Fittings
310	3" – 24" Slip Joint, Compact Fittings
320	3" – 12" Tapping Sleeve, Stainless Steel
400	Fire Hydrants
500	5/8" Disc. Water Meters
510	3/4" Disc. Water Meters
520	1" Disc. Water Meters
530	1-1/2" Disc. Water Meters
540	2" Disc. Water Meters
900	3" – 18" Plain Swing Check Valves
901	3" – 18" Tilting Disc Check Valves
990	Cast Iron Valve Box

Specifications for **3" – 64" Slip Joint, Ductile Iron Pipe**

MWS Item Number(s)	400 – 2" or 3" Iron Pipe	401 – 4" Iron Pipe
	402 – 6" Iron Pipe	403 – 8" Iron Pipe
	404 – 10" Iron Pipe	405 – 12" Iron Pipe
	410 – 16" Iron Pipe	411 – 18" Iron Pipe
	412 – 24" Iron Pipe	

Last Revision: September 25, 2002  
Date Written: March 5, 1998

**General:**

Pipe shall be ductile iron manufactured in accordance with the requirements of ANSI/AWWA C151/A21.51 or latest revision. Each pipe shall be hydrostatically tested and marked in accordance with Section 51-9 and 51-10. Furthermore, tensile and strength test shall be provided prior to acceptance in accordance with Section 51-12.

Push-On joints for such pipe shall be in accordance with ANSI/AWWA C111/A21.11 or latest revision.

Pipe thickness shall be designed in accordance with ANSI/AWWA C150/A21.5 or latest revision and shall be pressure class 350 unless otherwise noted on plans and specifications for project.

Pipe shall have cement mortar lining in accordance with ANSI/AWWA C104/A21.04 or latest revision.

**Approved Manufacture(s):**

- U.S. Pipe Company
- American Ductile Iron Pipe Company
- Griffin Pipe Products

Morristown Water System

Specification # 150

Specifications for **2"- 8" Slip Joint, PVC Pipe Class 200**

MWS Item Number(s)	601 – 2" PVC	602 – 6" PVC
	603 – 8" PVC	604 – 4" PVC

Last Revision:	March 5, 1998
Date Written:	March 5, 1998

**General:**

PVC pipe shall be 200 PSI (SDR-21), bear the NSF seal of approval and meet requirements of PS-22-70 and ASTM-D-2241. Type 1, 2, 150psi design stress compounds meeting ASTM-D-1784 specifications (PVC 1120) shall be used in the manufacture. Shall be furnished with integral bells and gaskets in 20-foot lengths.

**Approved Manufacture(s):**

Contractor to provide submittals for approval before installation.

Specifications for **2 – 24” Push On or Mechanical Joint, Resilient Seated Gate Valves**

MWS Item Number(s)	475 – 2” Valve	500 – 4” Valve	501 – 6” Valve
	502 – 8” Valve	503 – 10” Valve	504 – 12” Valve
	505 – 24” Valve	507 – 16” Valve	508 – 18” Valve

Last Revision: March 5, 1998  
Date Written: March 5, 1998

**General:**

- A. Valves shall be of the resilient seat type, non-rising stem, with o-ring seals. Valves shall be of the highest quality both as to materials and workmanship and shall conform to ANSI/AWWA C509-94 or latest revision.
- B. Valve body, bonnet and follower glands shall be cast of ductile iron conforming to ASTM A536. Shell thickness of body and bonnet component shall conform to Table 2 Sec. 4.4 to ANSI/AWWA C509-94 or latest revision.
- C. Valve body and bonnet shall be coated on all exterior and interior surfaces with a fusion bonded epoxy conforming to the requirements of AWWA “Standard for Protective Coatings for Valves and Hydrants” C550-81. Manufacture shall certify that the coating will conform to the following sections of the standard.
  - 1. Section 2 – Materials. Relating to the suitability of the coating for use in a potable water system.
  - 2. Section 3 – Coated Sample Testing. Relating to disbondment or blistering and impact damage.
- D. The valve shall be designed so that during operation, or cycling, of the valve, there is no friction or abrasion or rubbing together of gate and body that can wear away any rubber or epoxy and expose bare iron.
- E. The sealing mechanism shall consist of a single piece, solid, ductile iron wedge, completely encapsulated by a vulcanized synthetic rubber coating. The resilient sealing mechanism shall provide zero leakage at applicable design working pressure when installed with the line flow in either direction
- F. Valve shall be NSF certified, conforming to the requirement of ANSI/NSF Standard 61. Valves shall be labeled NSF.
- G. Gate valves for buried service shall be furnished with mechanical joint end connections unless otherwise shown on the drawings or specified herein.

**Approved Manufacture(s):**

- U.S. Pipe Company
- American Ductile Iron Pipe Company
- Muller
- M & H Valve Company

Specifications for **3” – 12” Tapping Valves**

MWS Item Number(s)	938 – 10” Tapping Valve	939 – 12” Tapping Valve
	940 – 6” Tapping Valve	941 – 8” Tapping Valve

Last Revision: March 5, 1998  
 Date Written: March 5, 1998

**General:**

- A. Valves used for tapping shall be of the resilient seat type, non-rising stem, with o-ring seals. Valves shall be of the highest quality both as to materials and workmanship and shall conform to ANSI/AWWA C509-94 or latest revision.
- B. Valve body, bonnet and follower glands shall be cast of ductile iron conforming to ASTM A536. Shell thickness of body and bonnet component shall conform to Table 2 Sec. 4.4 to ANSI/AWWA C509-94 or latest revision.
- C. Valve body and bonnet shall be coated on all exterior and interior surfaces with a fusion bonded epoxy conforming to the requirements of AWWA “Standard for Protective Coatings for Valves and Hydrants” C550-81. Manufacture shall certify that the coating will conform to the following sections of the standard.
  - 1. Section 2 – Materials. Relating to the suitability of the coating for use in a potable water system.
  - 2. Section 3 – Coated Sample Testing. Relating to disbondment or blistering and impact damage.
- D. The valve shall be designed so that during operation, or cycling, of the valve, there is no friction or abrasion or rubbing together of gate and body that can wear away any rubber or epoxy and expose bare iron.
- E. The sealing mechanism shall consist of a single piece, solid, ductile iron wedge, completely encapsulated by a vulcanized synthetic rubber coating. The resilient sealing mechanism shall provide zero leakage at applicable design working pressure when installed with the line flow in either direction
- F. Valve shall be NSF certified, conforming to the requirement of ANSI/NSF Standard 61. Valves shall be labeled NSF.
- G. End connections shall be mechanical joint and flanged. The flanged end shall include a special tapping lip that properly fits the counterbore of the tapping sleeve. The mechanical joint end shall meet MSS SP-113 to insure proper alignment of tapping machine.

**Approved Manufacture(s):**

- U.S. Pipe Company
- American Ductile Iron Pipe Company
- Muller
- M & H Valve Company

Specifications for **3" – 24" Mechanical Joint Compact Fittings**

MWS Item Number(s) 430-599 -- 3" through 24"  
Plugs, Tees, Bends, Crosses, Reducers, Sleeves, & Wyes

Last Revision: May 26, 2000  
Date Written: March 5, 1998

**General:**

Fittings shall be available in 4" through 16" sizes and shall be cast from ductile iron in accordance with ANSI/AWWA C153/A21.53 or latest revision with mechanical joint bells. Glands, bolts, nuts and gaskets shall be in accordance with requirements of ANSI/AWWA C153/A21.53 or latest revision and listed by an approved certifying agency as conforming to the requirements of ANSI/NSF 61. The working pressure rating shall be 350 psi. Fittings shall be coated with a 6-8 mil nominal thickness bonded epoxy conforming to the requirements of ANSI/AWWA C550 and C116/A21.16.

All fittings shall be supplied with accessories—glands, bolts, and standard styrene butadiene rubber (SBR) gaskets as per ANSI/AWWA C116/A21.16 or latest revision.

**Approved Manufacture(s):**

U.S. Pipe Company

American Ductile Iron Pipe Company

Griffin Pipe Products Company

Specifications for **4" – 16" Mechanical Joint and Push On Compact Tees**

MWS Item Number(s) 430-599 -- 4" through 16" Tees

Last Revision: May 26, 2000  
Date Written: March 5, 1998

**General:**

Fittings shall be available in 4" through 16" sizes and shall be cast from ductile iron in accordance with ANSI/AWWA C153/A21.53 or latest revision with mechanical joint or push on bells. Glands, bolts, nuts and gaskets shall be in accordance with requirements of ANSI/AWWA C153/A21.53 or latest revision and listed by an approved certifying agency as conforming to the requirements of ANSI/NSF 61. The working pressure rating shall be 350 psi. Fittings shall be coated with a 6-8 mil nominal thickness bonded epoxy conforming to the requirements of ANSI/AWWA C550 and C116/A21.16.

All fittings shall be supplied with accessories—glands, bolts, and standard styrene butadiene rubber (SBR) gaskets as per ANSI/AWWA C116/A21.16 or latest revision.

**Approved Manufacture(s):**

U.S. Pipe Company

American Ductile Iron Pipe Company

Griffin Pipe Products Company

Specifications for **3" – 24" Slip Joint, Compact Fittings**

MWS Item Number(s) 430-599 -- 3" through 24"  
Plugs, Tees, Bends, Crosses, Reducers, Sleeves, & Wyes

Last Revision: May 26, 2000  
Date Written: March 5, 1998

**General:**

Fittings shall be available in 4" through 16" sizes and shall be cast from ductile iron in accordance with ANSI/AWWA C153/A21.53 or latest revision. The working pressure rating shall be 350 psi. Fittings shall be slip joint in accordance with all applicable requirements of ANSI/AWWA C153/A21.53 or latest revision. Fittings shall be coated with a 6-8 mil nominal thickness bonded epoxy conforming to the requirements of ANSI/AWWA C550 and C116/A21.16.

A method of providing joint restraint within the socket shall be available when specified.

**Approved Manufacture(s):**

- U.S. Pipe Company
- American Ductile Iron Pipe Company
- Griffin Pipe Products

Specifications for **3"-12" Tapping Sleeves, Stainless Steel Body**

MWS Item Number(s)	948 6x6 Tapping Sleeve	949 12x6 Tapping Sleeve
	950 12x8 Tapping Sleeve	951 10x8 Tapping Sleeve
	952 18x6 Tapping Sleeve	953 18x8 Tapping Sleeve
	954 12" Tapping Sleeve	955 12x10 Tapping Sleeve
	956 10x6 Tapping Sleeve	957 16x6 Tapping Sleeve

Last Revision: March 5, 1998  
Date Written: March 5, 1998

**General:**

Tapping sleeves, stainless steel body, shall be compatible with any standard tapping valve and Muller CC-25 Drilling Machine. Outlet branch and flange shall be in compliance with AWWA Standard C-207, Class D ANSI 150lb drilling. Nuts, bolts, and washer to be 304 stainless steel.

**Approved Manufacture(s):**

- Ford Meter Box Company
- Romac Company
- Muller
- Smith-Blair

Specifications for	<b>Fire Hydrants</b>
MWS Item Number(s)	800
Last Revision:	September 2, 2004
Date Written:	March 5, 1998

**General:**

Fire Hydrants shall conform to the requirements of AWWA standard for Dry-Barrel Fire Hydrants (ANSI/AWWA C502-94) and in addition, shall be listed by Underwriters Laboratories and Factory Mutual Research Corp. Cast marks or other permanent marks shall be used to identify the fire hydrant as conforming to these standards.

Fire Hydrant shall also conform to the following supplementary specifications.

1. Hydrants shall be rated for 200 psi operating pressure and tested at 500 psi per Section 5.1 AWWA C502. Production Testing of each hydrant shall be performed at 500 psi to ensure proper assembly and operation and detect any imperfections. All iron parts as designed in Section 3.1.2 of AWWA C502-85 shall be ductile iron. Gray iron is not permitted, except for those parts which are designated to break upon traffic impact.
2. The **bury length** (distance from ground-line to insert of the hydrant inlet) shall be **42 inches**.
3. **Nozzles shall have two 2-1/2" hoses 180 degrees apart and one 4-1/2" pumper**. All nozzles shall be at the same elevation. Nozzle threads shall be National Standard Fire Hose Coupling Screw Thread as described in Appendix A of AWWA C502. Nozzle caps shall be provided with chains and gaskets. Nozzle caps shall have nut configuration the same as the hydrant-operating nut. Nozzles shall be reverse threaded into the upper barrel and mechanically locked in place.
4. Hydrant **main valve shall be 4-1/2" minimum** and shall be of the full compression design, openings against and closing against pressure. The main valve seat ring shall thread into bronze sub-seat and all the gaskets sealing the seat ring shall be on a bronze-to-bronze seating surface. The seat ring threads shall not serve as a pressure seal. The entire valve and rod assembly shall be removed by use of a small lightweight seat removal wrench.
5. The drain valves shall allow complete drainage of all residual water in the hydrant. The circumferential drain passage inside the hydrant shall be bronze on all surfaces.
6. All exterior bolting and fasteners below the ground-line shall be stainless steel. Plated steel bolts and nuts are not acceptable.
7. Hydrant shall be the breakaway type with a frangible ground-line and rod coupling designed to break upon traffic impact and prevent further damage to the hydrant and connecting pipe. The frangible coupling shall allow the upper section to be rotated to any desired position. Couplings that employ lugs, keeper devices or a breakaway barrel are not acceptable.
8. Hydrant **operating nut** shall be ductile iron or bronze and shall be **pentagonal in shape, 1-1/2" point to flat (AWWA Standard)**. The operating nut shall also function as a weather shield. Hydrant shall open left counterclockwise.
9. The operating machine shall utilize two "O" ring seals between the revolving nut and bronze-sheathed upper section of the valve rod. The top of the rod shall also be fitted with a travel step nut to limit downward travel of the rod. All-weather grease shall be used to provide permanent lubrication. A thermoplastic thrust washer shall be used to reduce friction in the thrust collar while opening the hydrant.
10. The hydrant inlet shall be **Mechanical Joint**

**Approved Manufacture(s):**

1. Muller
2. M & H Valve Company

Specifications for **5/8" Water Meters**  
 MWS Item Number(s) Unknown  
 Last Revision: March 23, 2003  
 Date Written: September 11, 1995

**General:**

Specification for Nutating Disc or Oscillating Piston cold water meters w/out spuds for use in measurement of potable cold water in residential, commercial, and industrial services where flow is in one direction only.

**Approved Manufactures:**

Badger	Model 25
Schlumberger	Model Neptune T-10
Sensus	Model SR-1 or SR-2
ABB	Model C-700

**Performance Conditions:**

Size	1/2" - 5/8"
Typical Operating Range	1/2 - 25 GPM
Low Flow	1/4 GPM
Maximum Continuous Flow	15 GPM
Pressure Loss	3.5 PSI at 15 GPM
Maximum Operating Temp.	80 Deg. F.
Maximum Operating Pres.	150 PSI
Register Type	Straight reading, permanently sealed magnetic drive w/ warranty
Register Capacity	10,000,000 Gallons
Meter Connections	Bronze to fit 1/2" Spud Thread
Meter Housing	Bronze
Bottom Plates	Bolted Bronze or Cast Iron
Measuring Chamber	Plastic
Meter Length	7-1/2"

**Construction:**

Meter should be constructed to meet or exceed AWWA Standards C710-90 Cold-Water Meters Displacement Type. Manufacture shall place Morristown Water System Identification number on exterior of meter lid. Morristown Water System shall supply identification number information. Manufacture shall provide Certified Test Record in accordance with Sec. 3.8 of AWWA C710-90, Standard for Cold-Water Meters-Displacement Type.

Specifications for **3/4" Water Meters**  
 MWS Item Number(s) Unknown  
 Last Revision: April 6, 2000

**General:**

Specification for Nutating Disc or Oscillating Piston type, positive displacement meter for use in measurement of potable cold water in residential, commercial, and industrial services where flow is in one direction only.

**Performance Conditions:**

Size	3/4"
Typical Operating Range	3/4 to 35 GPM
Low Flow	3/8 GPM
Maximum Continuous Flow	25 GPM
Pressure Loss	5 PSI at 25 GPM
Maximum Operating Temp.	80 Deg. F.
Maximum Operating Pres.	150 PSI
Register Type	Straight reading, permanently sealed magnetic drive w/ warranty
Registration	10 Gallons
Register Capacity	10,000,000 Gallons
Meter Connections	3/4" spud thread bronze
Meter Housing	Cast Bronze
Housing Top Plate	Bronze
Measuring Chamber	Plastic
Meter Length	7- 1/2"

**Construction:**

Meter should be constructed to meet or exceed AWWA Standards C710-90 or latest revision Cold-Water Meters Displacement Type. Manufacture should place Morristown Water System Identification number on exterior of meter lid. Identification number information shall be supplied by Morristown Water System. Manufacture shall provide Certified Test Record in accordance with Sec. 3.8 of AWWA C710-90, Standard for Cold-Water Meters-Displacement Type, Plastic Main Case; and Water Meters-Selection, Installation, Testing, or Maintenance.

**Approved Manufacture(s):**

Badger	Model 35
Schlumberger	Model Neptune T-10
Sensus	Model SR-1 or SR-2.

Specifications for **1" Water Meters**  
 MWS Item Number(s) Unknown  
 Last Revision: April 4, 2000

**General:**

Specification for Nutating Disc or Oscillating Piston type, positive displacement meter for use in measurement of potable cold water in residential, commercial, and industrial services where flow is in one direction only.

**Performance Conditions:**

Size	1"
Typical Operating Range	1-1/4" to 70 GPM
Low Flow	3/4 GPM
Maximum Continuous Flow	50 GPM
Pressure Loss	6.5 PSI at 50 GPM
Maximum Operating Temp.	80 Deg. F.
Maximum Operating Pres.	150 PSI
Register Type	Straight reading, permanently sealed magnetic drive w/ warranty
Registration	10 Gallons
Register Capacity	10,000,000 Gallons
Meter Connections	1" spud thread bronze
Meter Housing	Cast Bronze
Housing Top Plate	Bronze
Measuring Chamber	Plastic
Meter Length	10- 3/4"

**Construction:**

Meter should be constructed to meet or exceed AWWA Standards C710-90 or latest revision Cold-Water Meters Displacement Type. Manufacture should place Morristown Water System Identification number on exterior of meter lid. Identification number information shall be supplied by Morristown Water System. Manufacture shall provide Certified Test Record in accordance with Sec. 3.8 of AWWA C710-90, Standard for Cold-Water Meters-Displacement Type, Plastic Main Case; and Water Meters-Selection, Installation, Testing, or Maintenance.

**Approved Manufacture(s):**

Badger	Model 70
Schlumberger	Model Neptune T-10
Sensus	Model SR-1 or SR-2.

Specifications for **1-1/2" Water Meters**  
 MWS Item Number(s) Unknown  
 Last Revision: November 21, 2006

**General:**

Specification for Nutating Disc or Oscillating Piston type, positive displacement meter for use in measurement of potable cold water in residential, commercial, and industrial services where flow is in one direction only.

**Performance Conditions:**

Size	1-1/2"
Typical Operating Range	2-1/2 to 120 GPM
Low Flow	1-1/4 GPM
Maximum Continuous Flow	80 GPM
Pressure Loss	4.8 PSI at 80 GPM
Maximum Operating Temp.	80 Deg. F.
Maximum Operating Pres.	150 PSI
Register Type	Straight reading, permanently sealed magnetic drive w/ warranty
Registration	100 Gallons
Register Capacity	100,000,000 Gallons
Meter Connections	1-1/2" AWWA two bolt elliptical flange
<b>Test Plugs</b>	<b>1" NPT test plug</b>
Meter Housing	Cast Bronze
Housing Top Plate	Bronze
Measuring Chamber	Plastic
Meter Length	12-5/8"

**Construction:**

Meter should be constructed to meet or exceed AWWA Standards C710-90 or latest revision Cold-Water Meters Displacement Type. Manufacture should place Morristown Water System Identification number on exterior of meter lid. Identification number information shall be supplied by Morristown Water System. Manufacture shall provide Certified Test Record in accordance with Sec. 3.8 of AWWA C710-90, Standard for Cold-Water Meters-Displacement Type, Plastic Main Case; and Water Meters-Selection, Installation, Testing, or Maintenance.

**Approved Manufacture(s):**

Badger            Model 120

Specifications for **2" Water Meters**  
 MWS Item Number(s) Unknown  
 Last Revision: August 1, 2006

**General:**

Specification for Nutating Disc or Oscillating Piston type, positive displacement meter for use in measurement of potable cold water in residential, commercial, and industrial services where flow is in one direction only.

**Performance Conditions:**

Size	2"
Typical Operating Range	2 to 170 GPM
Low Flow	1 GPM
Maximum Continuous Flow	100 GPM
Pressure Loss	3.3 PSI at 100 GPM
Maximum Operating Temp.	80 Deg. F.
Maximum Operating Pres.	150 PSI
Register Type	Straight reading, permanently sealed magnetic drive w/warranty
Registration	100 Gallons
Register Capacity	100,000,000 Gallons
Meter Connections	2" AWWA two bolt elliptical flange
Test Plugs	1" NPT test plug
Meter Housing	Cast Bronze
Housing Top Plate	Bronze
Measuring Chamber	Plastic
Meter Length	15- 1/4"

**Construction:**

Meter should be constructed to meet or exceed AWWA Standards C710-90 or latest revision Cold-Water Meters Displacement Type. Manufacture should place Morristown Water System Identification number on exterior of meter lid. Identification number information shall be supplied by Morristown Water System. Manufacture shall provide Certified Test Record in accordance with Sec. 3.8 of AWWA C710-90, Standard for Cold-Water Meters-Displacement Type, Plastic Main Case; and Water Meters-Selection, Installation, Testing, or Maintenance.

**Approved Manufacture(s):**

Badger	Model 170
Neptune	Model T-10
Invensys	Model SR

Specifications for	<b>4" – 12" Plain Swing Check Valve</b>
MWS Item Number(s)	Unknown
Last Revision:	March 12, 1998
Date Written:	March 12, 1998

### **General**

Check valve shall be of the iron body, bronze mounted, full opening swing type. Valve clapper shall swing completely clear of the water way when valve is full open, permitting a "full flow" thru the valve equal to the nominal pipe diameter. Check valve shall comply with A.W.W.A. Standard C508-93 or latest revision.

### **Rating**

Check valve shall be rated for 150 psi water working pressure, 300 psi hydrostatic test for structural soundness. Seat tightness at rated working pressure shall be in accordance with valves shown in A.W.W.A. C-500 for gate valves and fully conform to A.W.W.A. C508-93.

### **End Configurations**

Check valve shall be furnished with mechanical joint end connections per A.W.W.A. C-111 without accessories.

### **Materials**

All cast iron shall conform to ASTM-A-126 Class B. Castings shall be clean and sound without defects that will impair their service. No plugging or welding of such defects shall be allowed. Clappers shall be cast iron, bronzed faced. Hinge pins shall be 18-8 Stainless Steel rotating in bronze plugs.

### **Design**

Check valve shall be constructed to permit top entry for complete removal of internal components without removing the valve from the line.

### **Painting**

The inside and outside of all valves, together with the working parts except bronze and machined surfaces, shall be coated in accordance with A.W.W.A. C5-8-93 standards.

### **Marking**

Marking shall be in accordance with A.W.W.A. C-508-93 and shall include size, working pressure, cast arrow to indicate direction of flow, name of manufacture, and year of manufacture.

Specifications for 4" -- 18" Tilting Disc Check Valve  
MWS Item Number(s) Unknown  
Last Revision: March 12, 1998  
Date Written: November 11, 1996

**General:**

The check valve shall be of the tilting disc. The tilting disc check valve shall consist of a circular disc with conical rim, hinged about a fixed pivot above its centerline and offset from the plane of the seat, seating against a body seat clamped between the two sections of the valve body.

**Construction:**

The body shall be two-piece, consisting of an entrance and a discharge section bolted together at an angle with the pipeline. An o-ring seal in a groove between the body flanges shall be in place to prevent leakage between the flanges when bolted together. The valve shall be complete with ANSI Class 125 flanges to mate with adjacent equipment. A body seat shall be clamped in place in a slot between the body sections. The body seat shall have a conical finish to mate with the disc seat. There shall be an inspection port provided in both the entrance and discharge section to provide visual access both upstream and downstream of the disc. An indicator shall be provided to show disc position for full range of travel. All valve casting shall be ASTM A126 Class C cast iron, ASTM A536 Grade 65-45-12 ductile iron, or ASTM A216 Grade WCB cast steel. Disc seating shall be bronze. Body seat ring shall be bronze.

**Testing:**

Seat and leakage testing shall in strict accordance with AWWA Standard C-508 latest edition for Swing Check Valves.

**Coating:**

Coating shall be two layers (5 mils minimum each coat.) First coat interior and exterior to be amine modified polyamide epoxy Amerlock 400 or approved equivalent. The second coat shall be the same as the first coat.

Specifications for	<b>16" Plain Swing Check Valve</b>
MWS Item Number(s)	Unknown
Last Revision:	March 12, 1998
Date Written:	March 12, 1998

**General**

Check valve shall be of the iron body, bronze mounted, full opening swing type. Valve clapper shall swing completely clear of the water way when valve is full open, permitting a "full flow" through the valve equal to the nominal pipe diameter. Check valve shall comply with A.W.W.A. Standard C508-93 or latest revision.

**Rating**

Check valve shall be rated for 150 psi water working pressure, 300 psi hydrostatic test for structural soundness. Seat tightness at rated working pressure shall be in accordance with valves shown in A.W.W.A. C-500 for gate valves and fully conform to A.W.W.A. C508-93.

**End Configurations**

Check valve shall be furnished with flanged end connections per A.W.W.A. C-111.

**Materials**

All cast iron shall conform to ASTM-A-126 Class B. Castings shall be clean and sound without defects that will impair their service. No plugging or welding of such defects shall be allowed. Clappers shall be cast iron, bronzed faced. Hinge pins shall be 18-8 Stainless Steel rotating in bronze plugs.

**Design**

Check valve shall be constructed to permit top entry for complete removal of internal components without removing the valve from the line.

**Painting**

The inside and outside of all valves, together with the working parts except bronze and machined surfaces, shall be coated in accordance with A.W.W.A. C5-8-93 standards.

**Marking**

Marking shall be in accordance with A.W.W.A. C-508-93 and shall include size, working pressure, cast arrow to indicate direction of flow, name of manufacture, and year of manufacture.

Specifications for	<b>Cast Iron Gate Valve Box - Complete</b>
MWS Item Number(s)	575
Last Revision:	March 5, 1998
Date Written:	March 5, 1998

**General:**

The iron used for these castings shall conform to the applicable portions of ASTM Standard for gray iron castings (A-48-64) class no. 25. They shall be made of clean, even grain, tough gray iron. The castings shall be smooth, true to pattern and free from projections, sand holes, wrap and other defects, which would interfere with the use of, or impair the serviceability of the castings. All castings shall be well cleaned before inspection, and shall be inspected before coating. Unless otherwise specified, all castings shall be coated with coal tar pitch varnish, to which sufficient oil has been added to make a smooth coating, tough and tenacious when cold, not tacky and brittle.

**Approved Manufacture(s):**

Contractor to provide submittals for approval before construction

## **Section 12 – Standard Details**

Index

Drawing Description

---

Utility Placement Detail

Pipe Embedment Detail

Fire Hydrant Assembly

Flushing Valve Detail

Typical Small Meter Setting 5/8" – 2" Disc.

Typical Large Meter Setting 2" – 6" Turbo or Compound

Tapping Saddle and Valve

Typical Buttness for Tees

Buttness for Horizontal Bends and Caps

Side View – Anchor Block & bearing Pads

Thrust Block Sizing

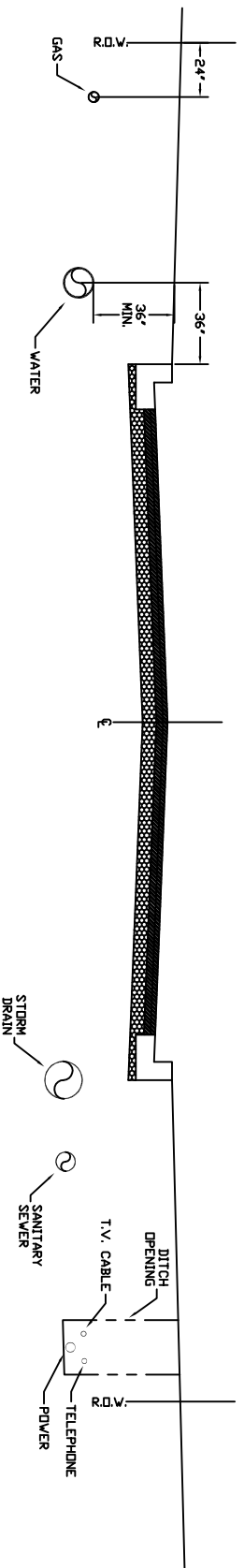

TYPICAL UTILITY CROSS SECTION

\*NOTE\* Right-Of-Way Width 50'  
 Road Width 25'  
 Utility Location will vary  
 depending on Road and R.O.W. size.

Standard Specifications & Drawings  
 for  
 Material & Pipe Line Installation

Utility Placement Detail

Feb. 25, 1998

Drawn By: M. Howard

No Scale



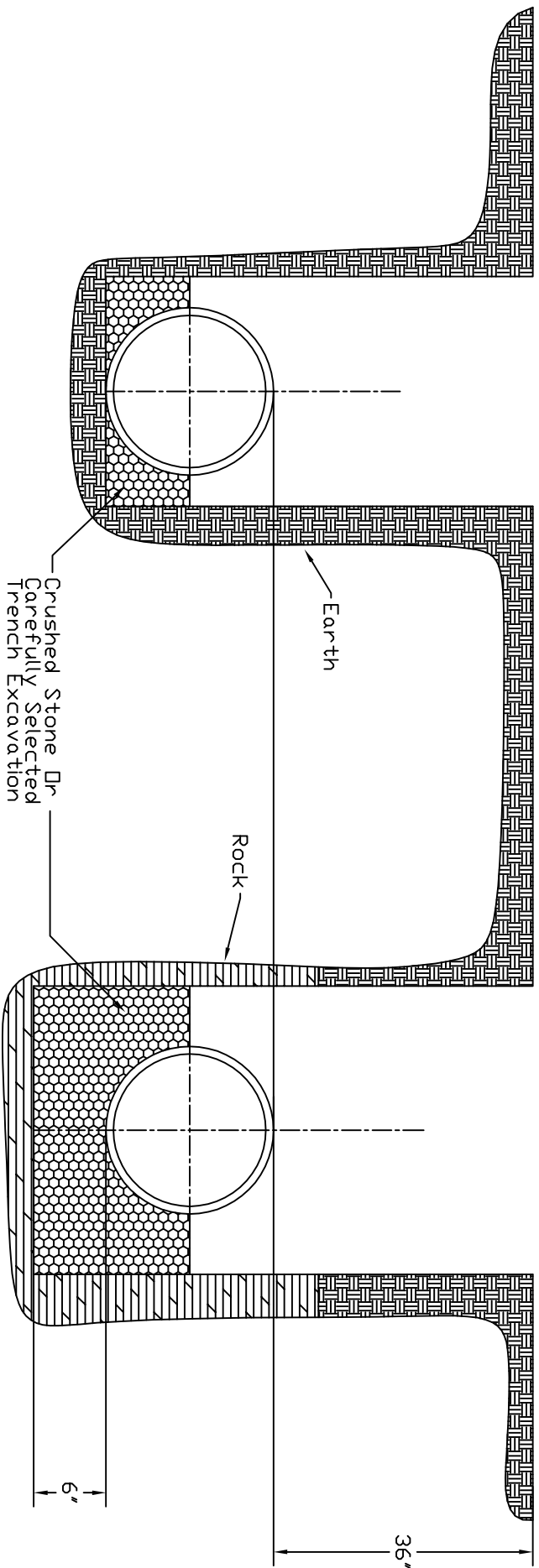

In Earth

In Rock

Standard Specifications & Drawings  
for  
Material & Pipe Line Installation

Pipe Embedment Detail

Feb. 25, 1998

Drawn By: M. Howard

No Scale



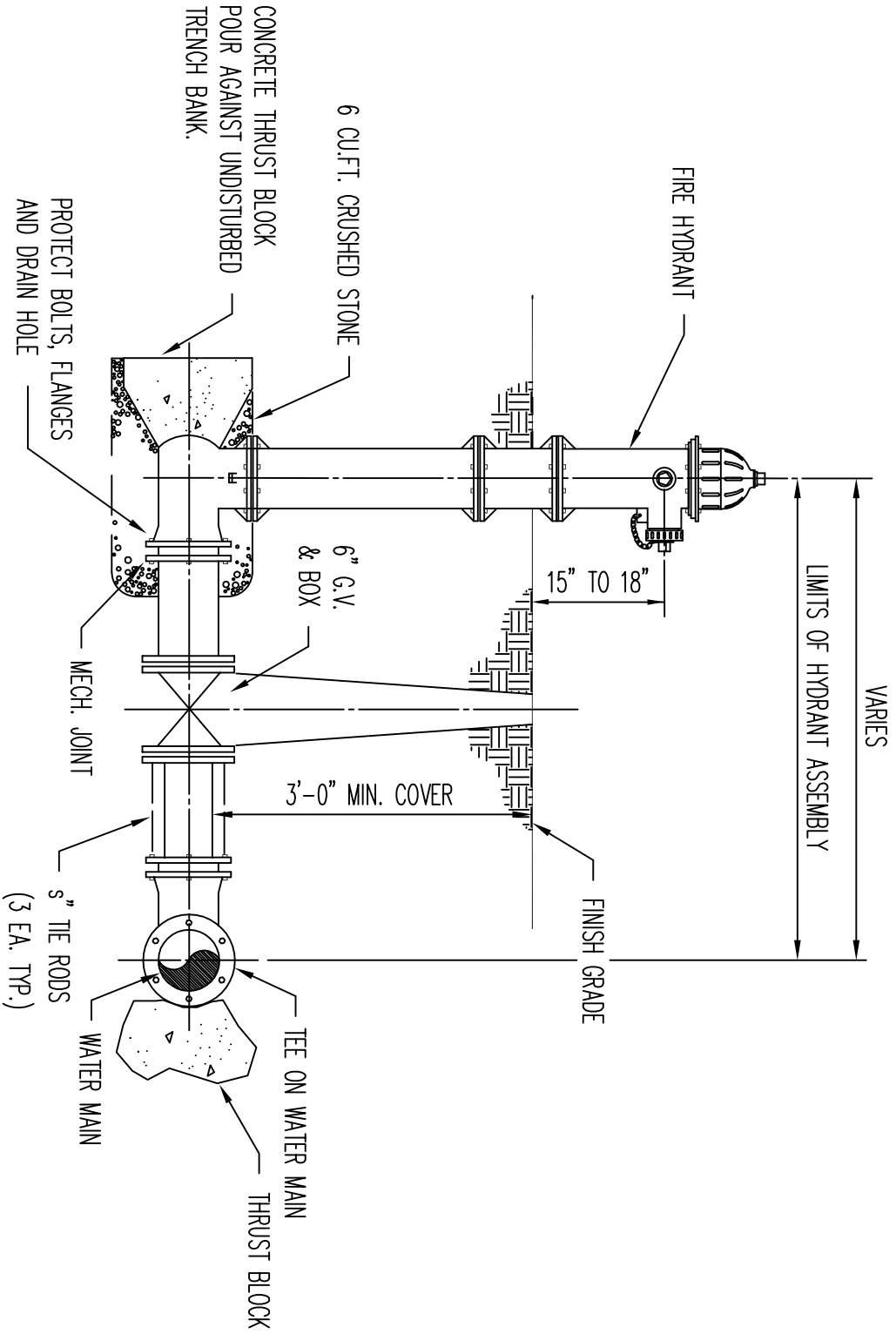

Standard Specifications & Drawings  
for  
Material & Pipe Line Installation

TYPICAL HYDRANT ASSEMBLY

Feb. 25, 1998

Drawn By: M. Howard

No Scale



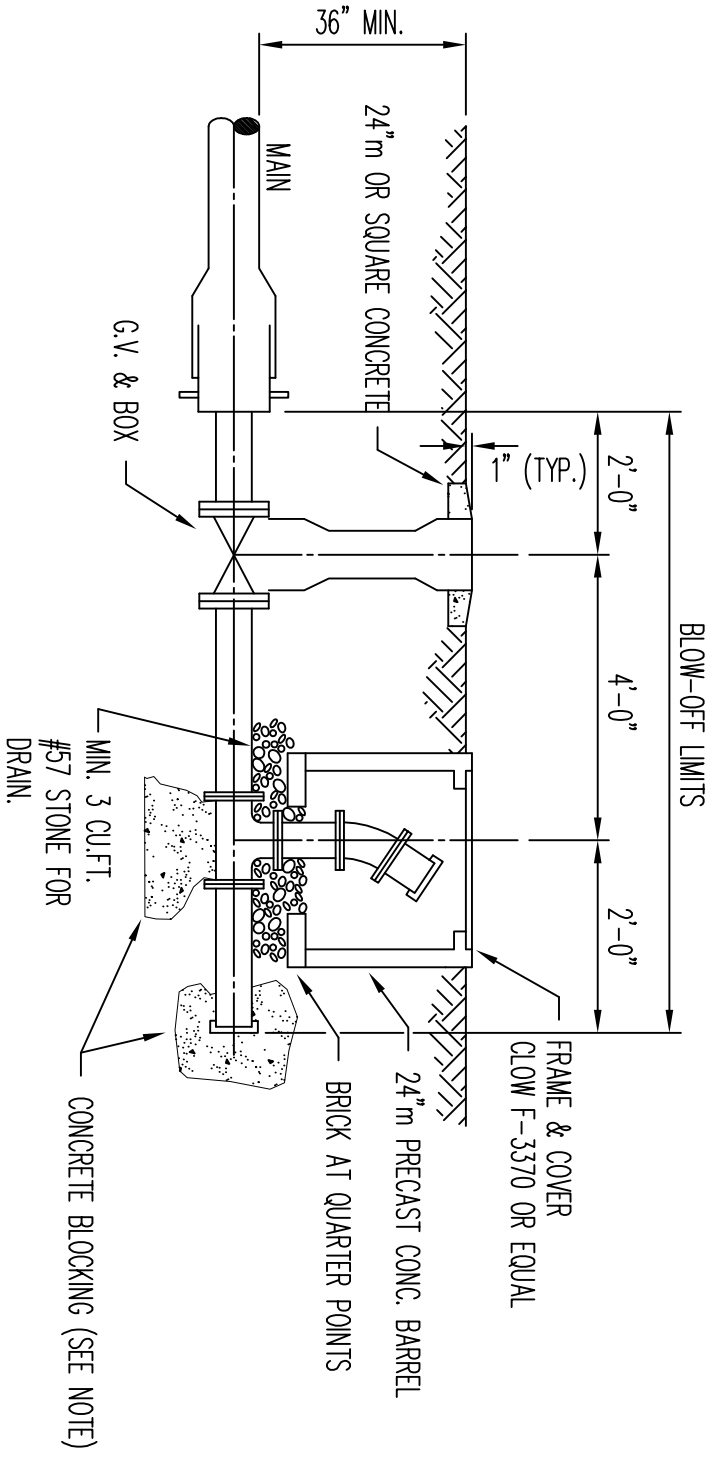

TYPICAL BLOW-OFF ASSEMBLY

Standard Specifications & Drawings  
for  
Material & Pipe Line Installation

Blow-Off Detail

Feb. 25, 1998

Drawn By: M. Howard

No Scale



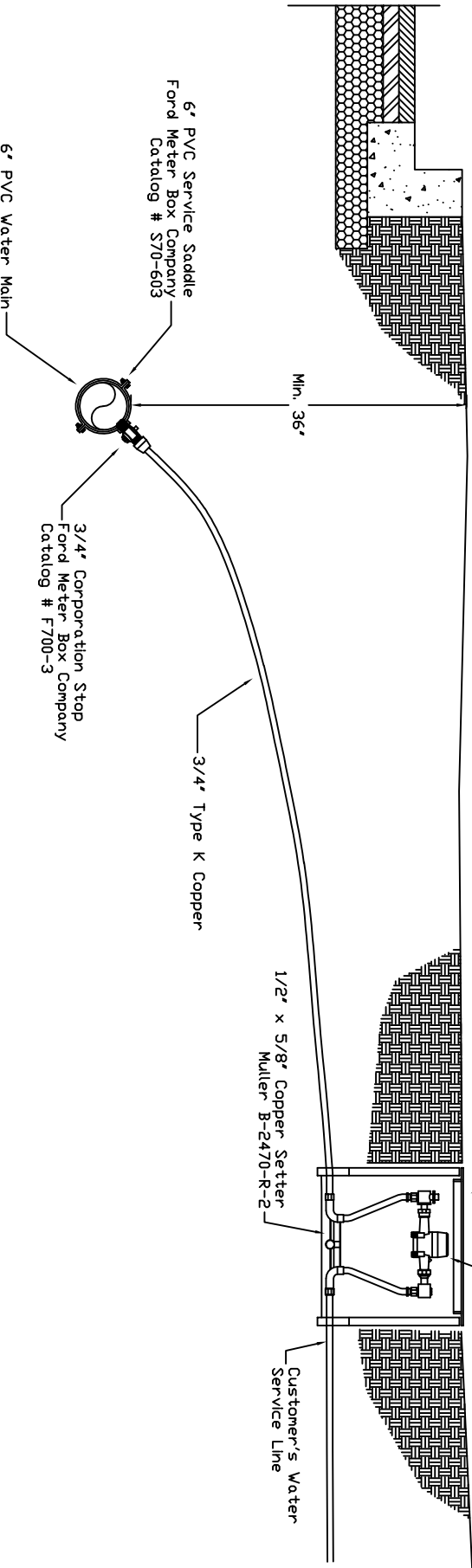

NOTE: CUSTOMER RESPONSIBILITY BEGINS AT THE METER SETTER COUPLING

Standard Specifications & Drawings  
for  
Material & Pipe Line Installation

# TYPICAL METER SETTING DETAIL

July 20, 2004

Drawn By: M. Howard

No Scale



### STANDARD SPRINKLER CONNECTION

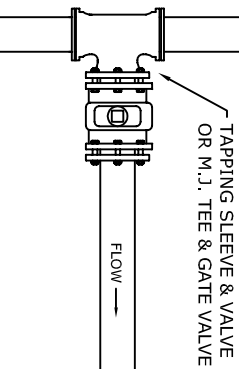

TAPPING SLEEVE & VALVE  
OR M.J. TEE & GATE VALVE

**FIRE SPRINKLER CONNECTION** (STANDARD SIZES 12", 10", 8", 6", & 4")  
IT IS MUS POLICY TO INSTALL THE SPRINKLER MAIN TO THE PROPERTY LINE OR  
INSTALL ONE JOINT OF PIPE DOWN STREAM OF ISOLATION VALVE, WHICHEVER  
IS CLOSEST TO MUS WATER MAIN. STATE OF TENNESSEE REQUIREMENT,  
SPRINKLER MAINS MUST BE INSTALLED BY A LICENSED SPRINKLER CONTRACTOR  
FROM THE WATER SUPPLIER'S TAP TO THE BUILDING. ALL LABOR, MATERIALS,  
AND EQUIPMENT COST ARE INCLUDED IN MUS CONNECTION FEES.

**BACKFLOW PREVENTER ASSEMBLY** (MUS APPROVED DEVICE)  
MUST BE INSTALLED BEFORE FIRST BRANCH OF FIRE PROTECTION SYSTEM.  
THIS ASSEMBLY MAY BE INSTALLED IN AN APPROVED PIT, ABOVE GROUND  
WITHIN A WEATHER PROOF ENCLOSURE, OR INSIDE A HEATED BUILDING. PLEASE  
SEE MUS FIRE SPRINKLER BACKFLOW PROTECTION POLICY FOR FURTHER DETAILS.  
INSTALLATION AND MAINTENANCE ARE OWNERS RESPONSIBILITIES.

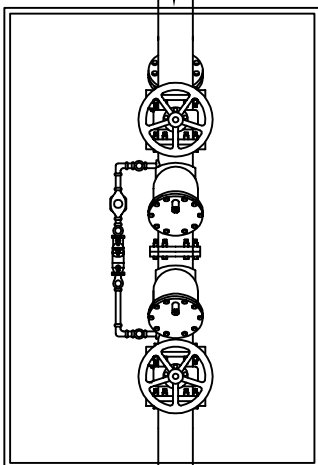

PROPERTY LINE/ R.O.W.

### STANDARD LARGE METER INSTALLATION

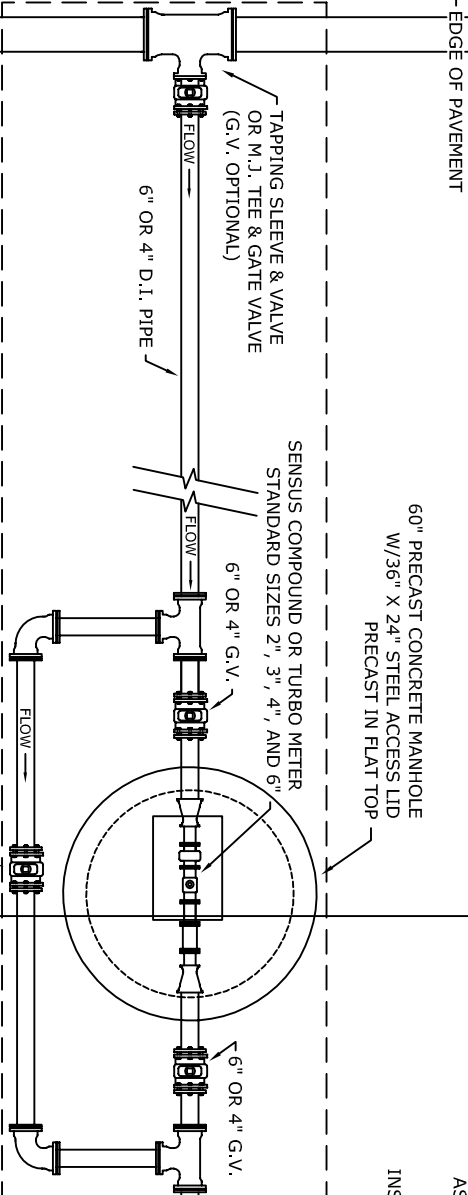

60" PRECAST CONCRETE MANHOLE  
W/36" X 24" STEEL ACCESS LID  
PRECAST IN FLAT TOP

TAPPING SLEEVE & VALVE  
OR M.J. TEE & GATE VALVE  
(G.V. OPTIONAL)

SENSUS COMPOUND OR TURBO METER  
STANDARD SIZES 2", 3", 4", AND 6"

6" OR 4" G.V.

6" OR 4" G.V.

IT IS MUS POLICY TO INSTALL WATER METERS  
ON OR NEAR THE PROPERTY LINE/R.O.W. OR AS  
CLOSE AS POSSIBLE TO EXISTING MUS WATER  
MAINS; FURTHERMORE, WATER METERS SHOULD  
BE LOCATED WITHIN GRASS AREAS. ALL LABOR,  
MATERIALS, AND EQUIPMENT COST ARE  
INCLUDED WITHIN MUS CONNECTION FEES

6" OR 4" D.I. BY-PASS  
WITH GATE VALVE  
NORMALLY CLOSED

**REDUCED PRESSURE BACKFLOW PREVENTER ASSEMBLY**  
(MUS APPROVED DEVICE) IN A PARALLEL INSTALLATION, MUST  
BE INSTALLED BEFORE FIRST BRANCH CONNECTION. THIS  
ASSEMBLY MAY BE INSTALLED ABOVE GROUND WITHIN A WEATHER  
PROOF ENCLOSURE OR WITHIN A HEATED BUILDING. PLEASE  
SEE MUS CROSS-CONNECTION POLICY FOR FURTHER DETAILS.  
INSTALLATION AND MAINTENANCE ARE OWNERS RESPONSIBILITIES.

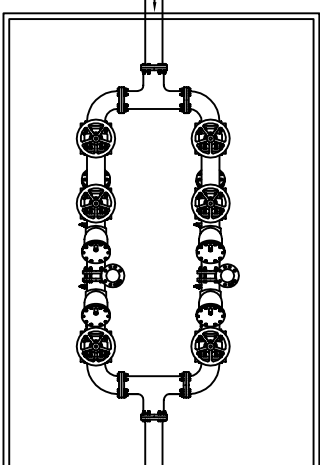

STATE, CITY, OR COUNTY ROAD

MUS WATER MAIN

EDGE OF PAVEMENT

TITLE: STANDARD INSTALLATION  
LARGE METERS (2", 3", 4", & 6") AND  
SPRINKLER CONNECTIONS (4", 6", 8", 10", & 12")

DRAWN BY: M. HOWARD  
DATE DRAWN: 05/02/06  
SHEET 1 OF 1  
WORK ORDER #:

Water Operations Office  
1833 Walkers Drive  
Morristown, TN 37814  
Phone (423) 586-1346  
Fax (423) 586-1241

General Manager  
William G. Swann, P.E.  
Water Operations Manager  
Robert H. Garrett



Commissioners  
George McGriffin, Chairman  
Harold Nichols, Secretary  
A.E. Gene Jolley, Member  
Lynn Etkins, Member

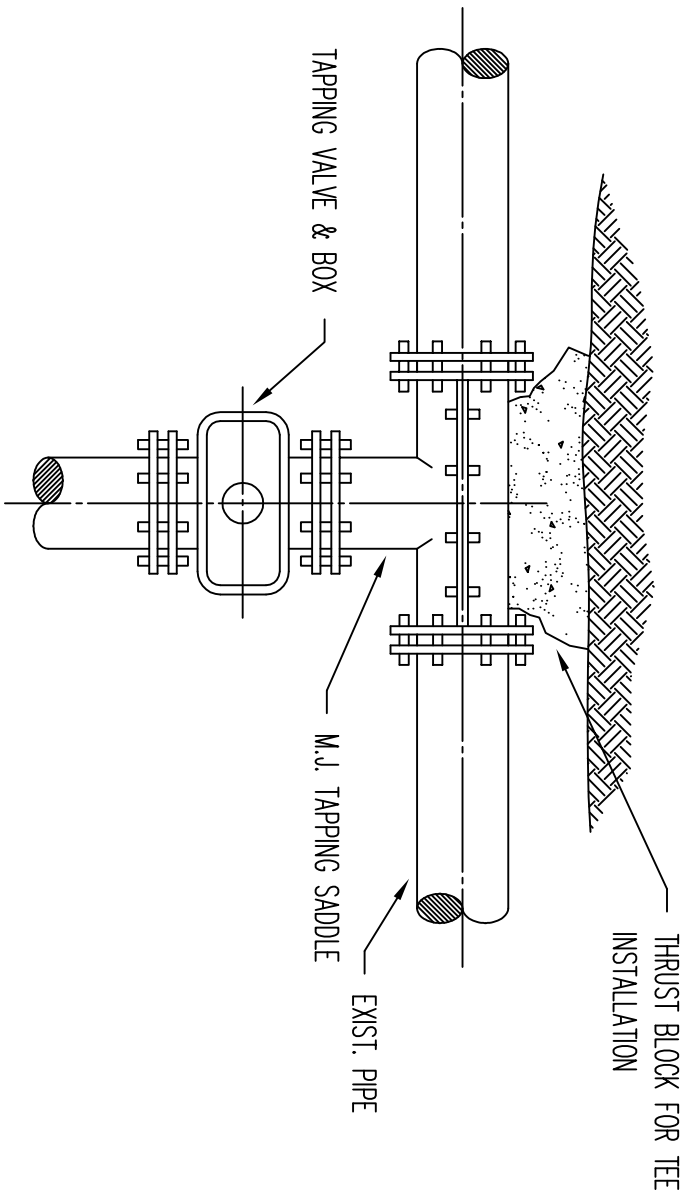

Standard Specifications & Drawings  
for  
Material & Pipe Line Installation

# TYPICAL TAPPING SADDLE & VALVE INSTALLATION

Feb. 25, 1998

Drawn By: M. Howard

No Scale



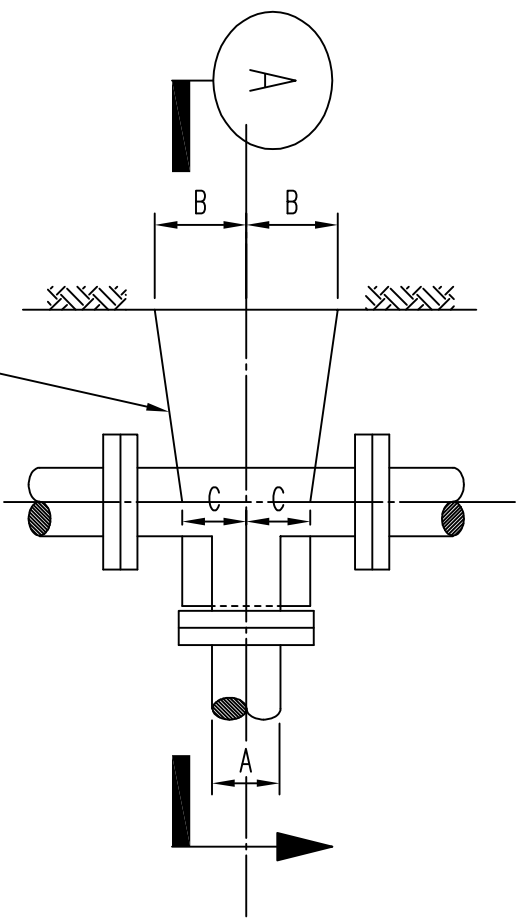

PLAN

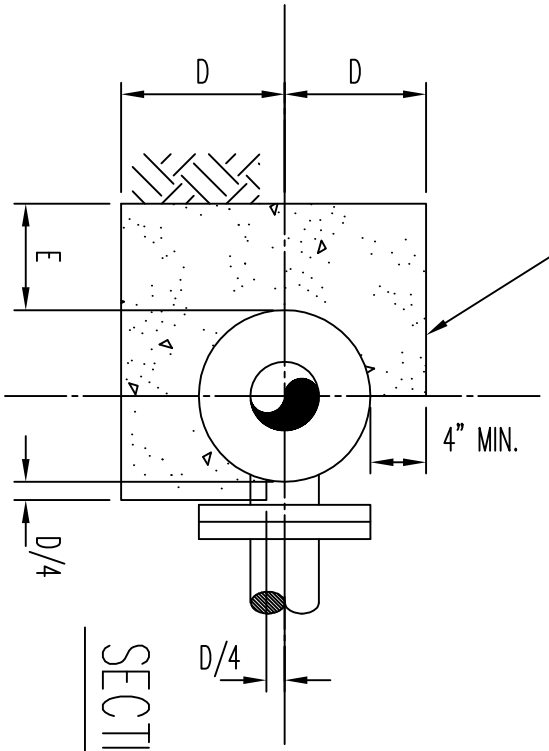

SECTION

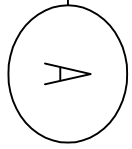

BUTRESS FOR TEES						
SIZE OF BRANCH						
A	6"	8"	10"	12"	16"	
B	7"	9"	1'-0"	1'-2"	1'-6"	
C	6"	8"	8"	8"	10"	
D	8"	10"	1'-0"	1'-3"	1'-8"	
E	8"	9"	10"	1'-0"	1'-2"	

CARRY CONCRETE TO SOLID GROUND

- NOTES:
1. ALL CONCRETE TO BE MIN. CLASS 'B' (2500 P.S.I.)
  2. BUTRESS DIMENSIONS SHOWN ARE MINIMUM. DIMENSIONS ARE BASED UPON SOIL BEARING PRESSURE OF 3000 P.S.F. OR SOIL BEARING PRESSURE IS LESS THAN 3000 P.S.F. SPECIAL BUTRESS DESIGN IS REQUIRED.

Standard Specifications & Drawings  
for  
Material & Pipe Line Installation

TYPICAL BUTRESS FOR TEES

Feb. 25, 1998

Drawn By: M. Howard

No Scale

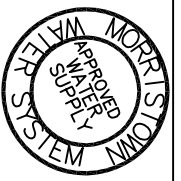

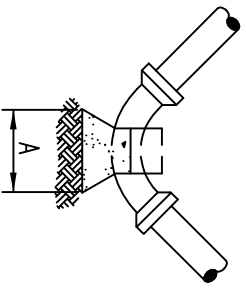

PLAN

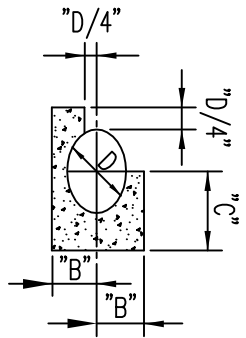

SECTION

BUTRESS FOR HORIZONTAL BENDS

BUTRESS FOR HORIZONTAL BENDS						
BEND	6"	8"	10"	12"	16"	
1/32	A	6"	8"	10"	1'-0"	1'-4"
	B	7"	8"	9"	10"	1'-0"
	C	7"	7"	8"	8"	9"
1/16	A	9"	1'-0"	1'-6"	1'-9"	2'-3"
	B	7"	8"	9"	10"	1'-0"
	C	8"	9"	10"	11"	1'-2"
1/8	A	1'-3"	1'-8"	2'-1"	2'-6"	3'-4"
	B	7"	8"	9"	11"	1'-3"
	C	8"	9"	10"	11"	1'-2"
1/4	A	2'-0"	2'-6"	3'-0"	3'-6"	5'-0"
	B	6"	9"	1'-0"	1'-3"	1'-6"
	C	1'-10"	1'-9"	1'-8"	1'-7"	1'-5"

NOTES:

- 1) ALL CONCRETE TO BE CLASS "B" 2500 P.S.I.
- 2) BUTRESS DIMENSIONS SHOWN ARE MINIMUM. DIMENSIONS BASED UPON SOIL BEARING PRESSURE OF 3000 P.S.F. AND STATIC WATER PRESSURE OF 150 P.S.I. WHERE SOIL BEARING PRESSURE IS LESS THAN 300 P.S.F. SPECIAL BUTRESS DESIGN IS REQUIRED.

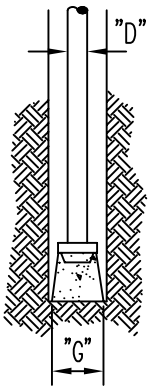

PLAN

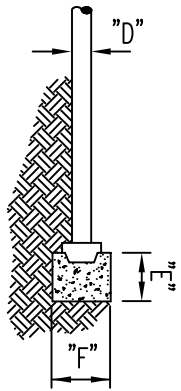

SECTION

BUTRESS FOR HORIZONTAL CAPS						
D	6"	8"	10"	12"	16"	20"
E	6"	8"	8"	10"	1'-0"	1'-4"
F	1'-0"	1'-4"	1'-8"	2'-0"	2'-8"	3'-3"
G	1'-5"	1'-11"	2'-5"	2'-10"	3'-9"	4'-9"

BUTRESS FOR CAPS

BUTRESS FOR HORIZONTAL BENDS & CAPS

Standard Specifications & Drawings  
for  
Material & Pipe Line Installation

Feb. 25, 1998

Drawn By: M. Howard

No Scale



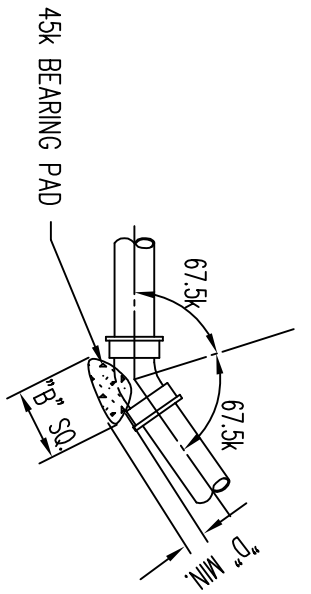

45° OR 22.5° BENDS

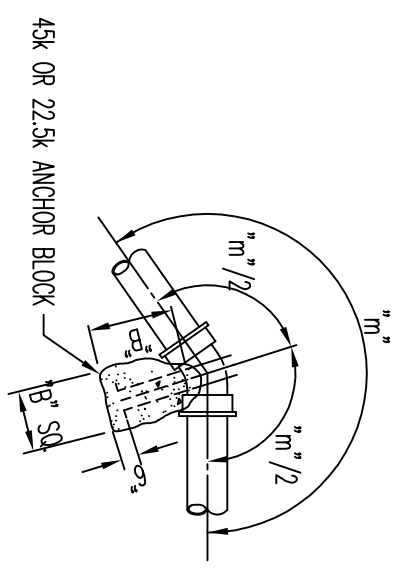

45K OR 22.5K ANCHOR BLOCK

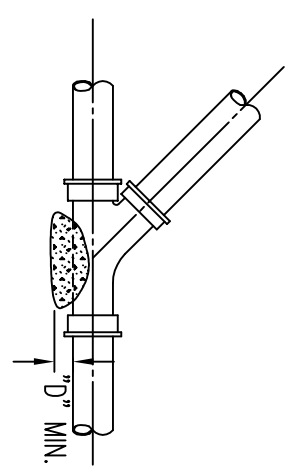

WYE

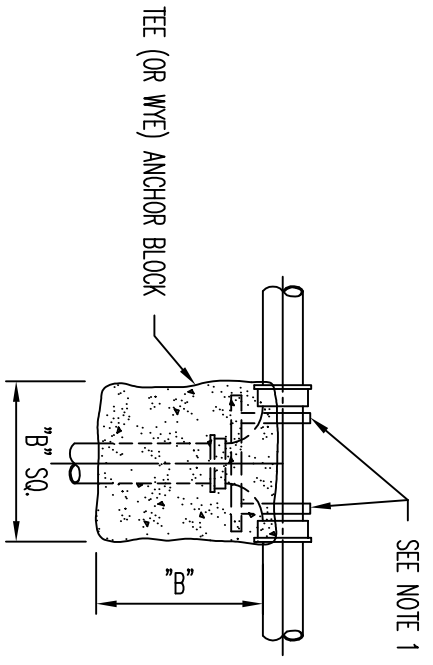

SEE NOTE 1

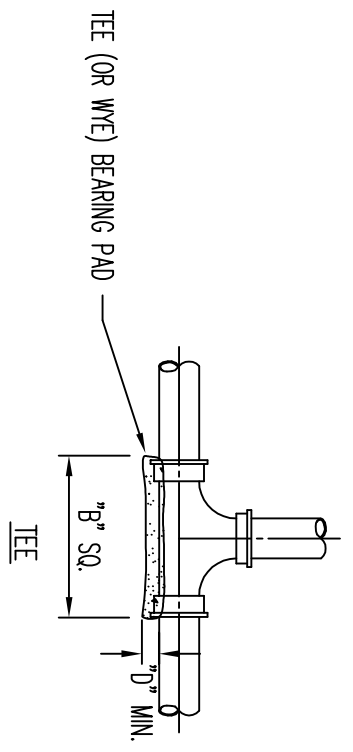

TEE

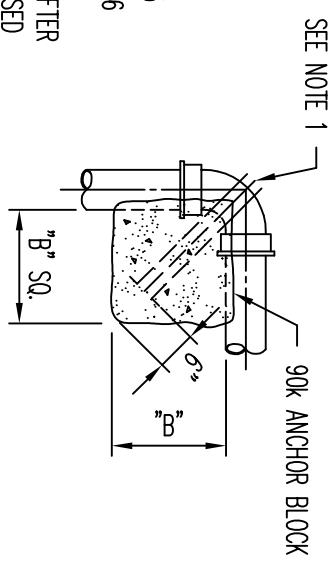

SEE NOTE 1

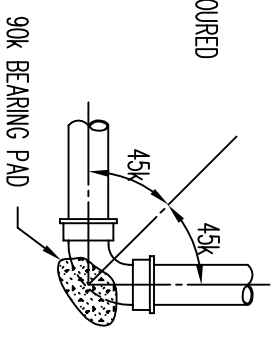

90° BENDS

- NOTE
1. ANCHOR BARS: 4" THRU 6" PIPE 2 #5  
8" THRU 16" PIPE 2 #6
  2. ANCHOR BARS TO BE HOTDIP GALV. AFTER FABRICATION. COMPLETELY COAT EXPOSED BARS AFTER INSTALLATION WITH TWO COATS OF BITUMINOUS MASTIC
  3. ALL BEARING PADS TO BE POURED ON UNDISTURBED SOIL

Standard Specifications & Drawings  
for  
Material & Pipe Line Installation

SIDE VIEW-ANCHOR BLOCK & BEARING PADS

Feb. 25, 1998

Drawn By: M. Howard

No Scale



PIPE (IN.)	THRUST BLOCKS							
	90° BENDS		45° BENDS		22.5° BENDS		WYES & TEES	
B	D	REINF. (E.W.)	B	D	REINF. (E.W.)	B	D	REINF. (E.W.)
2	1.0'	0.7'	—	1.0'	0.7'	—	1.0'	0.7'
3	1.0'	0.7'	—	1.0'	0.7'	—	1.0'	0.7'
4	1.0'	0.7'	—	1.0'	0.7'	—	1.2'	0.7'
6	1.4'	0.7'	—	1.0'	0.7'	—	1.6'	0.7'
8	1.8'	0.8'	—	1.4'	0.7'	—	2.2'	1.0'
10	2.3'	1.0'	—	1.7'	0.8'	—	2.7'	1.0'
12	2.7'	1.0'	—	2.0'	0.8'	—	3.2'	1.0'
14	3.2'	1.0'	4 #5	2.4'	1.0'	3 #5	3.8'	1.0'
16	3.6'	1.0'	5 #5	2.7'	1.0'	3 #5	4.3'	1.2'
18	4.1'	1.2'	5 #5	3.0'	1.0'	4 #5	4.9'	1.2'
20	4.5'	1.2'	5 #5	3.4'	1.0'	4 #5	5.4'	1.2'
24	5.5'	1.2'	6 #5	4.0'	1.0'	5 #5	6.5'	1.5'
30	6.8'	1.5'	8 #5	5.0'	1.2'	6 #5	8.1'	1.7'
36	8.2'	1.7'	9 #5	6.0'	1.3'	7 #5	9.7'	1.8'
42	9.6'	1.8'	10 #5	7.0'	1.5'	8 #5	11.3'	2.0'

**GENERAL NOTES**

1. CONTRACTOR SHALL BE RESPONSIBLE FOR PROPER APPLICATION OF THRUST RESTRAINT SYSTEM TO PREVENT MOVEMENT OF PIPE AND FITTINGS.
2. SYSTEM SHOWN IS DESIGNED FOR 150 P.S.I. PRESSURE, 2' FT. COVER, AND SOIL BEARING CAPACITY OF 3000 P.S.F. MINIMUM. WHERE THIS SYSTEM IS INAPPROPRIATE BECAUSE OF UNSTABLE SOIL OR OTHER CONDITIONS, SUBMIT DETAILS OF ALTERNATE SYSTEM TO ENGINEER FOR APPROVAL.
3. USE THRUST BLOCKS FOR 4" THRU 16" FITTINGS IN HORIZONTAL PLANE; USE ANCHOR BLOCKS AND BEARING PADS FOR 4" THRU 16" FITTINGS IN VERTICAL PLANE; USE RESTRAINED JOINT SYSTEM FOR 18" AND LARGER SIZE FITTINGS.
4. ALL FITTINGS IN VERTICAL PLANE, AND ALL FITTINGS 18" AND LARGER SHALL HAVE RESTRAINED JOINTS.
5. RESTRAINED JOINT DISTANCES FOR TEES APPLY TO BRANCH ONLY.
6. WHERE ONE END OF TEE IS PLUGGED, USE "DEAD END" THRUST BLOCK AT PLUG AND BEHIND TEE, OR USE "DEAD END" RESTRAINED JOINT SYSTEM ON BRANCH AND CONNECTED END OF TEE.
7. WHERE CLAMPS ARE APPLIED TO P.V.C. PIPE, PROVIDE " NEOPRENE PAD BETWEEN PIPE AND CLAMP.

Standard Specifications & Drawings  
for  
Material & Pipe Line Installation

# Thrust Block Sizing

Feb. 25, 1998

Drawn By: M. Howard

No Scale

